

IMPORTANT SAFETY NOTES



WARNING

RISK OF ELECTRIC SHOCK

BEFORE YOU BEGIN

- Read these instructions completely and carefully.
- The installation and connection of the luminaire must be done when switched off and by qualified people. Make sure no voltage while installation.

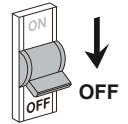

CAUTION

MAINTENANCE

- To avoid injuries, disconnect power to the light and allow the unit to cool down before performing maintenance.
- Perform visual, mechanical and electrical inspections on a regular basis. We recommend routine checks to be made on an annual basis. Frequency of use and environment should determine this.
- The Covers should be cleaned periodically as needed to ensure continued photometric performance. Clean the Cover with a damp, non-abrasive, lintfree cloth. If not sufficient, use mild soap or a liquid cleaner. Do not use an abrasive, strong alkaline or acid cleaner as damage may occur.
- Inspect the topside on the luminaire to ensure that it is free of any obstructions or contamination (i.e.excessive dust build-up). Clean with a non-abrasive cloth if needed.



This product contains a light source of energy efficiency class B.

Products

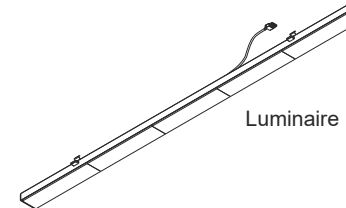

Optional Accessories

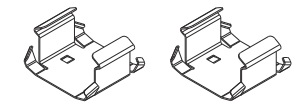

Special extra spring

Optional

1010718

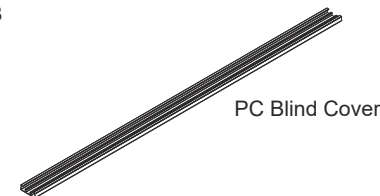

Optional Accessories

1010719

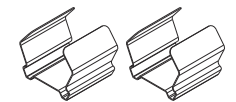

Special extra spring

Optional Plug

3-Pin

5-Pin

1009201
3-Pin plug



1009196
3-Pin plug



1009200
3-Pin plug



1009198
3-Pin plug



1009197
3-Pin plug



1009199
3-Pin plug Wago



1009195
3-Pin plug Wago

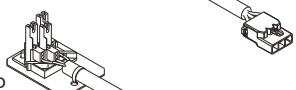

1009206
5-Pin plug



1009203
5-Pin plug



1009202
5-Pin plug Wago

















1009204
5-Pin plug



1009205
5-Pin plug Wago



	<p>DA - Henviisning om bortskafning (EU) Produktet må ikke bortskaffes sammen med husholdningsaffaldet! Produkter med dette symbol skal i henhold til direktivet (WEEE) om affald af elektrisk og elektronisk udstyr bortskaffes via de lokale indsamlingssteder for gamle el-apparater! Gamle batterier og gamle akkumulatører, der ikke er fast indbygget i det gamle apparat, og pærer, som uden at blive beskadiget kan tages ud af det gamle apparat, skal før aflevering på en genbrugsstation fjernes fra det gamle apparat uden beskadigelse. Distributører er i henhold til de gældende lovskrævede bestemmelser forpligtet til at tage imod gamle apparater fra en slutbruger. Det gamle apparat kan også sendes til følgende adresse til bortskaffelse i Tyskland: SLV GmbH, Technischer Service, Werkstrasse 8-10, 52531 Übach-Palenberg, Tyskland</p>
	<p>PL - Wskazówka dotycząca utylizacji (Unia Europejska) Nie wolno wyrzucać produktu do śmieci domowych! Produkty oznakowane tym symbolem należy utylizować zgodnie z wytycznymi (WEEE) dotyczącymi starych urządzeń elektrycznych i elektronicznych w miejscowych punktach gromadzenia odpadów elektrycznych! Zużyte baterie i akumulatory, które nie są wbudowane w zużyte urządzenie, jak również lampy, które można wyjąć ze zużytego urządzenia w sposób nieniszczący, należy w sposób nieniszczący oddzielić od zużytego urządzenia przed przekazaniem go do punktu zbiórki. Zgodnie z obowiązującymi przepisami dystrybutorzy są zobowiązani do odbioru zużytych urządzeń od użytkownika końcowego. Zużyte urządzenie można również wysłać na poniższy adres w celu utylizacji na terenie Niemiec: SLV GmbH, Technischer Service, Werkstrasse 8-10, 52531 Übach-Palenberg, Niemcy</p>
	<p>RU - Указание по утилизации (Европейский Союз) Не утилизировать прибор вместе с бытовыми отходами! Продукты с подобным обозначением в соотв. с Положением (WEEE) по утилизации старых электрических и электронных приборов необходимо утилизировать через специальные пункты сбора старых электроприборов! Перед доставкой в пункт сбора необходимо отделить от старого устройства неразрушающим способом старые батареи и аккумуляторы, которые не заключены внутри старого устройства, а также лампы, которые можно извлечь из старого устройства неразрушающим способом. Согласно существующему законодательству дистрибьюторы обязаны принимать старые устройства от конечного пользователя. Старый прибор можно также отправить по следующему адресу для утилизации на территории Германии: SLV GmbH, Technischer Service, Werkstrasse 8-10, 52531 Übach-Palenberg, Германия</p>
	<p>SV - Anvisningar för sophantering (Europeiska Unionen) Produkten får ej kastas i hushållssoporna! Produkter som är märkta med denna symbolen ska kastas i enlighet med riktlinjerna (WEEE) för elektriska och elektroniska apparater på de lokala uppsamlingsställena för el- och elektroniskskrot. Förbrukade batterier och akkumulatörer, som inte innesluts av aktuellt WEEE, t.ex. lampor, och som på ett icke-destruktivt sätt kan tas loss, ska innan WEEE lämnas till insamlingsstället separeras från den aktuellt WEEE. Distributörer är i enlighet med gällande lagstiftning skyldiga att ta hand om WEEE från slutanvändaren. Den gamla apparaten kan också skickas till följande adress för avfallshantering inom Tyskland: SLV GmbH, Technischer Service, Werkstrasse 8-10, 52531 Übach-Palenberg, Tyskland</p>
	<p>TR - Tasfiye açıklaması (Avrupa Birliği) Ürünü ev çöplüyle birlikte atmayın! Bu sembolü taşıyan ürünler, elektroteknik ve elektronik eski aletlerin yerel elektronik eski aletler toplama yerinde tasfiye edilmesi (WEEE) yönetmeliğine bağlıdır. Eski cihaz kapsamına girmeyen eski piller ve eski akümülatörler ve de eski cihazdan parçalanmadan çıkarılabilen lambalar, kayıt merkezine teslim edilmeden önce eski cihazdan parçalanmadan çıkarılmalıdır. Satıcılar ilgili yasal yükümlülüklerine göre eski cihazları son kullanıcılardan geri almakla yükümlüdür. Eski cihaz Almanya içinde imha edilmek üzere aşağıdaki adrese de gönderilebilir: SLV GmbH, Technischer Service, Werkstrasse 8-10, 52531 Übach-Palenberg, Almanya</p>
	<p>HU - Hulladékkezelés (Európai Unió) A termékét ne a hágyományos háztartási hulladékkal együtt dobja ki! A fenti jellel ellátott termékeket a WEEE, irányelv szerint az elektromos és elektronikus termékek számára kihelyezett hulladékgyűjtőbe tegye! Az olyan elemeket és akkumulátorokat, melyek nem zártan vannak a használt készülékbe helyezve valamint a használt készülékből roncsolás nélkül eltávolítható lámpákat a gyűjtőhelyen történő leadást megelőzően károsítás nélkül el kell távolítani. A fergalmazók a vonatkozó jogi előírásoknak megfelelően kötelesek visszavenni a végfelhasználótól a használt készülékeket. A régi készüléket a következő címre is elküldheti Németországon belüli ártalmatlanításra: SLV GmbH, Technischer Service, Werkstrasse 8-10, 52531 Übach-Palenberg, Németország</p>

	<p>DE - Entsorgung (Europäische Union) Produkt nicht im Hausmüll entsorgen! Produkte mit diesem Symbol sind entsprechend der Richtlinie (WEEE) über Elektro- und Elektronik-Altgeräte über die örtlichen Sammelstellen für Elektro-Altgeräte zu entsorgen! Altbatterien und Altakkumulatoren, die nicht vom Altgerät umschlossen sind, sowie Lampen, die zerstörungsfrei aus dem Altgerät entnommen werden können, sind vor der Abgabe an einer Erfassungsstelle vom Altgerät zerstörungsfrei zu trennen. Vertreiber sind, nach den jeweiligen gesetzlichen Verpflichtungen, verpflichtet Altgeräte von einem Endnutzer zurückzunehmen. Zur Entsorgung kann das Altgerät innerhalb Deutschlands auch an folgende Adresse versendet werden: SLV GmbH, Technischer Service, Werkstrasse 8-10, 52531 Übach-Palenberg</p>
	<p>EN - Disposal (European Union) Do not dispose the product with the regular household waste! Products marked with this sign must be disposed according to the directive (WEEE) on electrical and electronic devices at local collection points for such devices! Waste batteries and accumulators, which are not enclosed by the waste equipment, and lamps, which are removable non-destructively from the waste equipment are to be separated non-destructively from the waste equipment before turning to a local collection point. Distributors are, according to particular legislation, obligated to take back waste equipment from the final holder. For disposal within Germany the waste equipment may be send to the following address: SLV GmbH, Technischer Service, Werkstrasse 8-10, 52531 Übach-Palenberg, Germany</p>
	<p>FR - Information de recyclage (Union européenne) Ne recyclez pas le produit avec les ordures ménagères ! Les produits qui présentent ce symbole sont à recycler suivant la directive (WEEE) relative aux déchets d'équipements électriques et électroniques, via des points de collecte pour appareils électriques usagés ! Les piles et accus usagés qui ne sont pas incorporés dans l'appareil usagé, ainsi que les lampes qui peuvent être retirées de l'appareil usagé sans être détruites, doivent être retirés de l'appareil usagé sans être remis au Recyparc. Conformément à leurs obligations légales respectives, les distributeurs sont tenus de reprendre les appareils usagés d'un utilisateur final.</p> <div style="display: flex; justify-content: space-around; align-items: center;"> <div style="text-align: center;">  <p>FR Cet appareil se recycle</p> <p>À DÉPOSER EN MAGASIN OU À DÉPOSER EN DÉCHÈTERIE</p> <p>Points de collecte sur www.quefairedemesdechets.fr Privilégiez la réparation ou le don de votre appareil !</p> </div> <div style="text-align: center;">  <p>FR Cette batterie se recycle</p> <p>À DÉPOSER EN MAGASIN OU À DÉPOSER EN DÉCHÈTERIE</p> <p>Points de collecte sur www.quefairedemesdechets.fr</p> </div> </div> <p>Pour l'élimination, l'appareil usagé peut également être envoyé en Allemagne à l'adresse suivante : SLV GmbH, Technischer Service, Werkstrasse 8-10, 52531 Übach-Palenberg, Allemagne</p>
	<p>ES - Indicaciones para la eliminación (Unión Europea) ¡No tirar el producto con la basura doméstica! Los productos con este símbolo deben eliminarse, de acuerdo con la directiva (WEEE) sobre residuos de aparatos eléctricos y electrónicos, llevándolos a los puntos de recogida selectiva de aparatos eléctricos y electrónicos locales. Las baterías y los acumuladores recargables que no se hallen protegidos por el aparato viejo, así como las lámparas, extraídas sin romperlas del aparato viejo, deben desmontarse sin llegar a alterarlas antes de entregarlos a un punto de recogida. Los distribuidores están obligados a recoger los aparatos viejos de un usuario final según las obligaciones legales pertinentes. El aparato antiguo también puede enviarse a la siguiente dirección para su eliminación dentro de Alemania: SLV GmbH, Technischer Service, Werkstrasse 8-10, 52531 Übach-Palenberg, Alemania</p>
	<p>IT - Istruzioni per lo smaltimento (Unione Europea) Non smaltire il prodotto con i rifiuti domestici! I prodotti con questo simbolo devono essere smaltiti, nel rispetto della Direttiva (WEEE) sui rifiuti di apparecchiature elettriche ed elettroniche, nei punti di raccolta locale ad essi adibiti! Verificare sul sito www.slvitalia.it il corretto metodo di smaltimento del presente materiale. Le batterie e gli accumulatori usati non racchiusi nell'apparecchio usato e le lampade rimovibili dall'apparecchio usato senza venire distrutte, devono essere divise dall'apparecchio usato senza venire distrutte, prima di essere consegnate in un punto di raccolta. I rivenditori sono tenuti, secondo i rispettivi obblighi legali, a ritirare gli apparecchi usati dal consumatore finale. Il vecchio apparecchio può anche essere inviato al seguente indirizzo per lo smaltimento in Germania: SLV GmbH, Technischer Service, Werkstrasse 8-10, 52531 Übach-Palenberg, Germania</p>
	<p>NL - Afvalverwijdering (Europese Unie) Het product niet via het huishoudelijk afval weggoeien! Producten met dit symbol dienen in overeenstemming met richtlijn (WEEE) via elektrische en elektronische apparatuur bij de plaatselijke inzamelpunten voor elektrisch afval te worden verwijderd! Afgedankte accu's en accumulatoren die niet in het afgedankte apparaat zijn ingebouwd, zoals lampen die zonder beschadigingen uit het apparaat kunnen worden verwijderd, dienen voorafgaand aan de afgifte aan de betreffende instantie voor afgedankt apparaat, niet-destructief verwijderd te worden. De verkopers zijn op basis van de betreffende wettelijke regelgeving, verplicht afgedankte apparaten van een eindgebruiker terug te nemen. Het oude apparaat kan ook naar het volgende adres worden gestuurd voor verwijdering binnen Duitsland: SLV GmbH, Technischer Service, Werkstrasse 8-10, 52531 Übach-Palenberg, Duitsland</p>

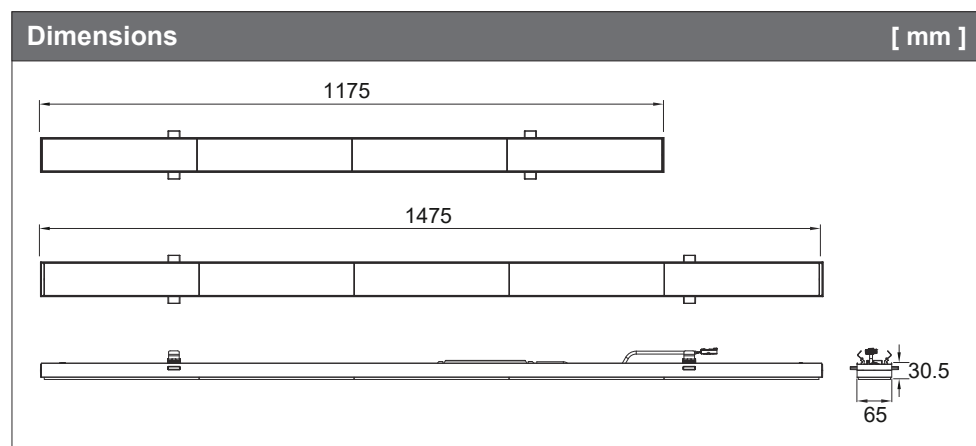

Installation Steps

1

Please check existing lable on the old system, and find the corresponding model in the compatibility list.

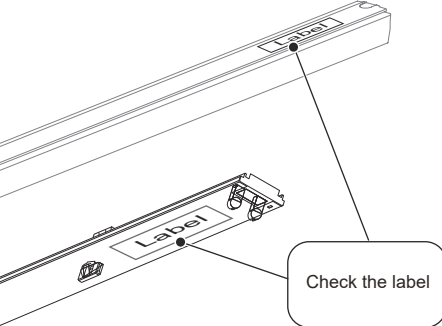

2 Remove old part

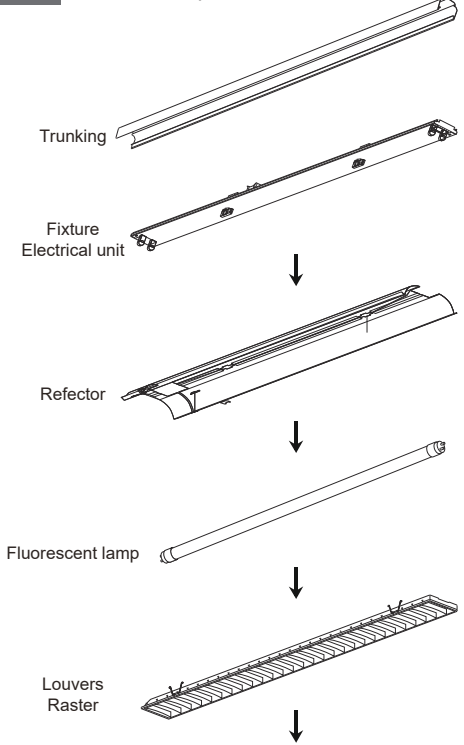

Trunking

Fixture Electrical unit

Reflector

Fluorescent lamp

Louvers Raster

Installation Steps

- 3** Before installation, please cut the tension straps to ensure that the pressingspring is in a released state

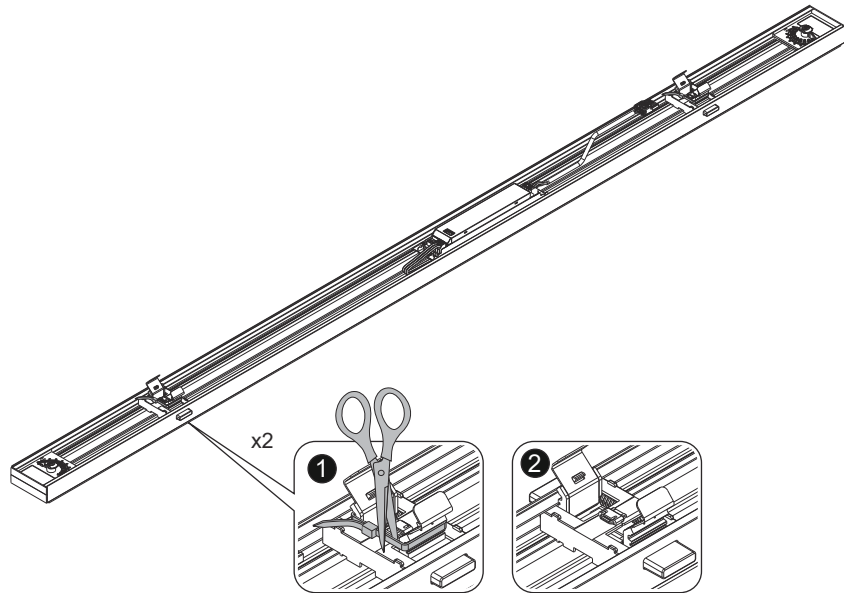

Installation PC Blind cover

- 2** Mounting Blind Cover

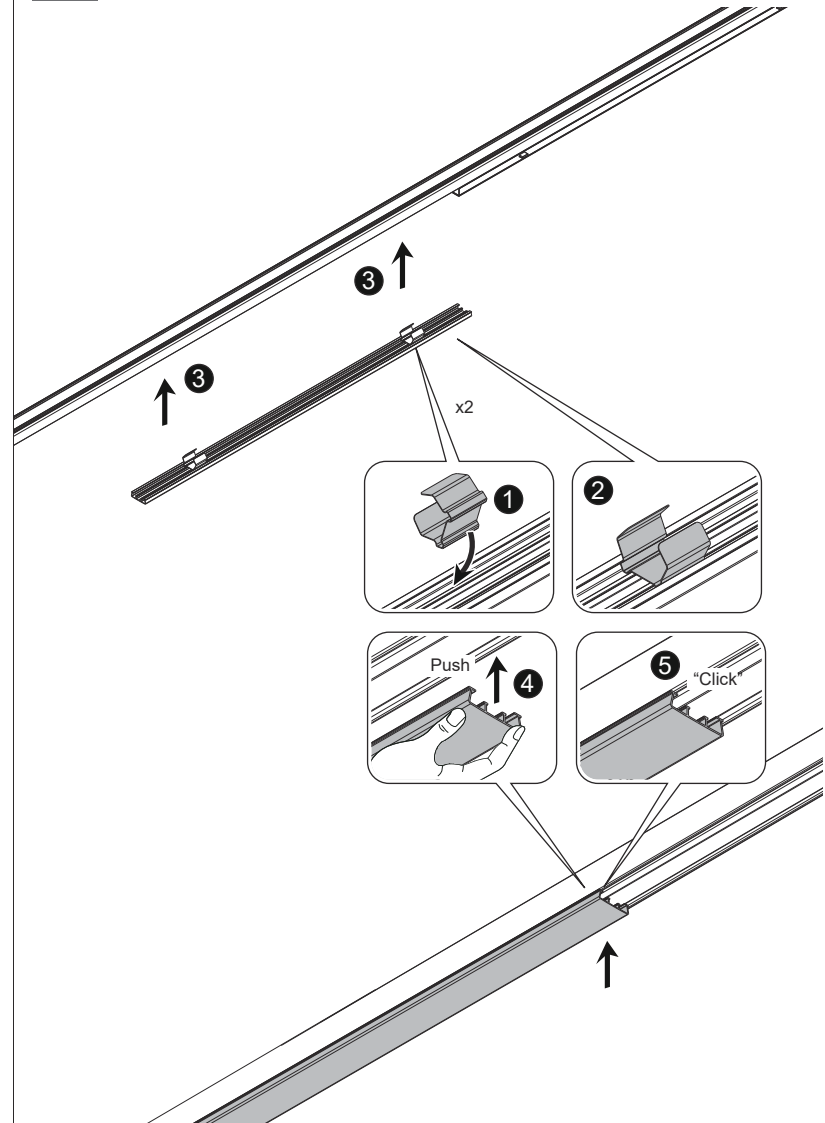

Installation PC Blind cover

- 1 Cut to desired length
(Option)

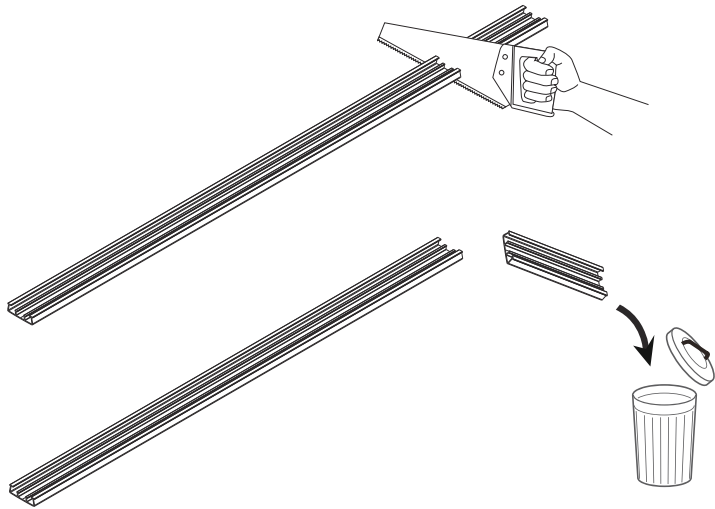

Installation Steps

- 4 Adjust to desired length (See table 1 and 2)

1175mm

A=1175mm
B=1178mm
C=1184mm
D=1194mm
E=1220mm
F=1225mm
G=1228mm
H=1230mm
I=1234mm
J=1237mm

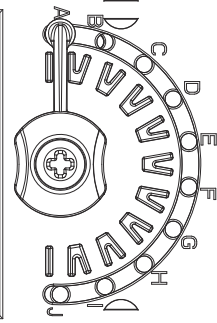

1475mm

A=1475mm
B=1478mm
C=1484mm
D=1494mm
E=1520mm
F=1525mm
G=1528mm
H=1530mm
I=1534mm
J=1537mm

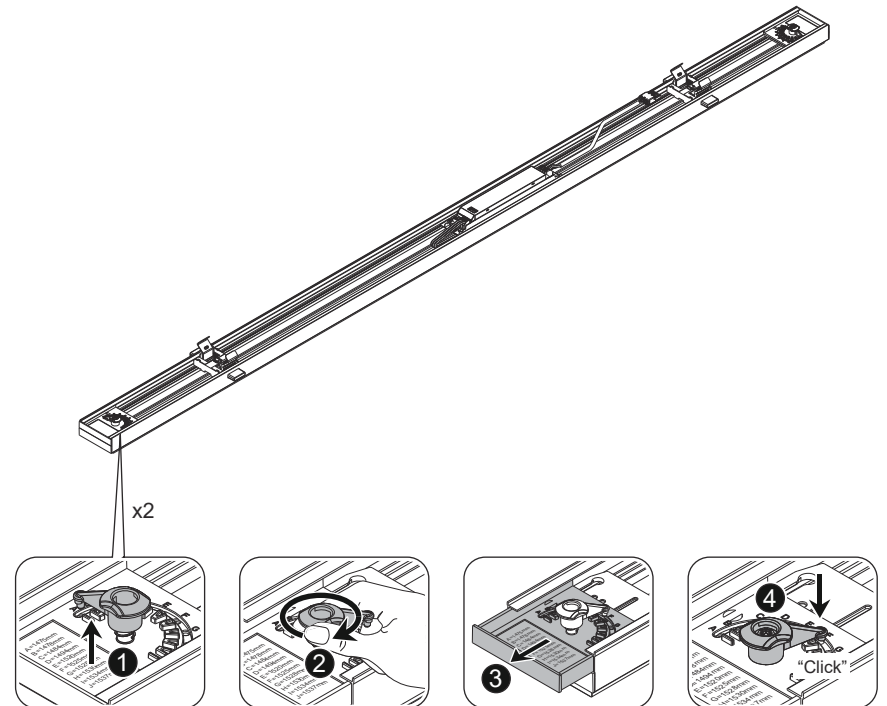
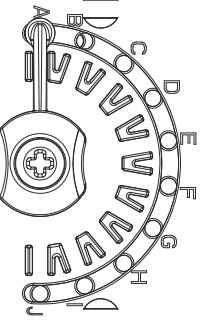

Installation Steps

5-a Wattage setting

ON/OFF

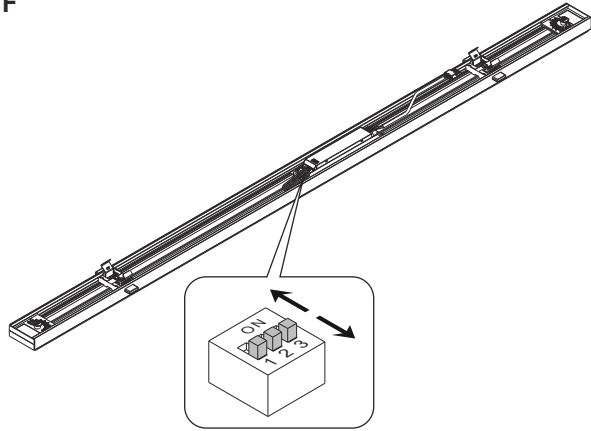

ON 1 2 3	Output current [mA]	Switch position			Power [W]	1009187, 1009188 1009189, 1009190					
		1	2	3		3500K		4000K		5000K	
						Light effect [lm/W]	Flux [lm]	Light effect [lm/W]	Flux [lm]	Light effect [lm/W]	Flux [lm]
	550	ON	ON	ON	75	177.9	13340	192.4	14432	182.8	13710
	500	ON	ON	OFF	68	180.1	12245	193.7	13174	185.1	12588
	450	ON	OFF	ON	61	182.5	11135	194.9	11891	187.6	11443
	400	ON	OFF	OFF	54	184.5	9965	196.0	10582	189.7	10243
	350	OFF	ON	ON	46	186.7	8586	196.6	9044	191.7	8820
	300	OFF	ON	OFF	40	187.8	7510	196.6	7862	192.9	7717
	250	OFF	OFF	ON	33	188.5	6220	195.9	6466	193.9	6398
	200	OFF	OFF	OFF	26	187.4	4873	193.7	5036	192.8	5012

ON 1 2 3	Output current [mA]	Switch position			Power [W]	1009179, 1009180 1009181, 1009182					
		1	2	3		3500K		4000K		5000K	
						Light effect [lm/W]	Flux [lm]	Light effect [lm/W]	Flux [lm]	Light effect [lm/W]	Flux [lm]
	550	ON	ON	ON	60	177.6	10657	191.6	11498	182.3	10937
	500	ON	ON	OFF	55	179.6	9877	192.8	10606	184.4	10140
	450	ON	OFF	ON	50	182.0	9099	193.9	9697	186.7	9334
	400	ON	OFF	OFF	44	183.7	8083	194.4	8555	188.3	8285
	350	OFF	ON	ON	38	185.1	7033	194.7	7398	190.0	7218
	300	OFF	ON	OFF	32	186.2	5958	194.7	6229	191.0	6112
	250	OFF	OFF	ON	26	186.2	4840	193.4	5028	191.1	4968
	200	OFF	OFF	OFF	21	184.1	3867	190.2	3993	189.1	3970

Compatible list

Table 2 (1475mm)

Finished size with adjusting the End caps	Trunking Brand	Trunk	Connectors-3pin	Connectors-5pin
H=1530mm	TRX TRZ		1009195	/
J=1537mm	090554/098287		1009195	/
A=1475mm	ZX1 T5		1009197	/
F=1525mm	ZX1 T8		1009197	/
A=1475mm	ZX2 T5		1009198	1009204
F=1525mm	ZX2 T8		1009198	1009204
C=1484mm	PRESTIGE T5		1009198	1009204
I=1534mm	PRESTIGE T8		1009198	1009204
A=1475mm	E-line 07650xx		1009199	1009205
H=1530mm	E-line 07690xx		1009199	1009205
H=1530mm	SDT/ST		1009199	1009205
H=1530mm	TR50W		1009199	1009205
H=1530mm	SV70 SV75		1009199	1009205
H=1530mm	Planos		1009199	1009205
G =1530mm	PNR 2003-nu		1009199	1009205
G =1530mm	PNR 1995-2003		1009200	/
D=1494mm	E-STN T5		1009200	/
J=1537mm	E-STN T8		1009200	/
B=1478mm	TTX400 T5		1009201	1009206
G=1528mm	TTX400 T8		1009201	1009206
B=1478mm	MAXOS T5		1009201	1009206
G=1528mm	MAXOS T8		1009201	1009206

Compatible list

Table 1 (1175mm)

Finished size with adjusting the End caps	Trunking Brand	Trunk	Connectors-3pin	Connectors-5pin
H=1230mm	TRX TRZ		1009195	/
J=1237mm	090554/098287		1009195	/
A=1175mm	ZX1 T5		1009197	/
F=1225mm	ZX1 T8		1009197	/
A=1175mm	ZX2 T5		1009198	1009204
F=1225mm	ZX2 T8		1009198	1009204
C=1184mm	PRESTIGE T5		1009198	1009204
l=1234mm	PRESTIGE T8		1009198	1009204
A=1175mm	E-line 07650xx		1009199	1009205
H=1230mm	E-line 07690xx		1009199	1009205
H=1230mm	SDT/ST		1009199	1009205
H=1230mm	TR50W		1009199	1009205
H=1230mm	SV70 SV75		1009199	1009205
H=1230mm	Planos		1009199	1009205
G =1228mm	PNR 2003-nu		1009199	1009205
G =1228mm	PNR 1995-2003		1009200	/
D=1194mm	E-STN T5		1009200	/
J=1237mm	E-STN T8		1009200	/
B=1178mm	TTX400 T5		1009201	1009206
G=1228mm	TTX400 T8		1009201	1009206
B=1178mm	MAXOS T5		1009201	1009206
G=1228mm	MAXOS T8		1009201	1009206

Installation Steps

5-b Wattage setting DALI

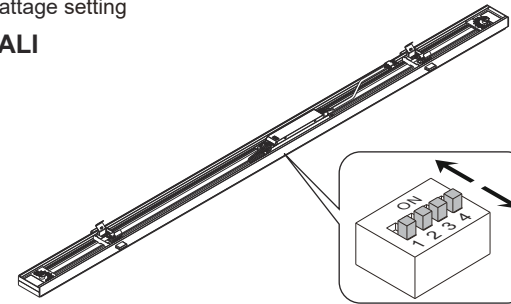

ON 1 2 3 4	Output current [mA]	Switch position				Power [W]	1009183, 1009184 1009185, 1009186					
		1	2	3	4		3500K		4000K		5000K	
							Light effect [lm/W]	Flux [lm]	Light effect [lm/W]	Flux [lm]	Light effect [lm/W]	Flux [lm]
550	ON	ON	ON	ON	60	173.2	10391	191.6	11498	182.3	10937	
525	OFF	ON	ON	ON	57	172.8	9850	191.4	10909	181.9	10369	
500	ON	OFF	ON	ON	55	175.1	9633	192.8	10606	184.4	10140	
475	OFF	OFF	ON	ON	52	175.0	9099	192.0	9985	184.2	9578	
450	ON	ON	OFF	ON	49	177.3	8689	193.9	9503	186.7	9147	
425	OFF	ON	OFF	ON	46	177.0	8142	193.2	8888	186.3	8571	
400	ON	OFF	OFF	ON	44	178.9	7871	194.4	8555	188.3	8285	
375	OFF	OFF	OFF	ON	41	178.9	7335	194.0	7954	188.3	7721	
350	ON	ON	ON	OFF	38	180.5	6857	194.7	7398	190.0	7218	
325	OFF	ON	ON	OFF	35	180.6	6322	194.8	6818	190.1	6655	
300	ON	OFF	ON	OFF	32	181.5	5807	194.7	6229	191.0	6112	
275	OFF	OFF	ON	OFF	29.5	182.3	5379	195.8	5776	191.9	5662	
250	ON	ON	OFF	OFF	27	181.5	4901	193.4	5221	191.1	5159	
200	OFF	ON	OFF	OFF	22	179.6	3951	190.2	4184	189.1	4159	

ON 1 2 3 4	Output current [mA]	Switch position				Power [W]	1009191, 1009192 1009193, 1009194					
		1	2	3	4		3500K		4000K		5000K	
							Light effect [lm/W]	Flux [lm]	Light effect [lm/W]	Flux [lm]	Light effect [lm/W]	Flux [lm]
550	ON	ON	ON	ON	75	168.5	12637	187.5	14063	177.4	13302	
525	OFF	ON	ON	ON	71	169.6	12038	188.2	13363	178.5	12672	
500	ON	OFF	ON	ON	68	170.7	11607	188.9	12845	179.7	12218	
475	OFF	OFF	ON	ON	64	171.7	10991	189.5	12125	180.8	11570	
450	ON	ON	OFF	ON	61	173.3	10573	190.2	11600	182.5	11129	
425	OFF	ON	OFF	ON	57	173.1	9869	190.8	10877	182.3	10388	
400	ON	OFF	OFF	ON	54	174.0	9397	191.4	10336	183.2	9891	
375	OFF	OFF	OFF	ON	50	175.0	8751	191.9	9595	184.2	9212	
350	ON	ON	ON	OFF	47	176.1	8275	192.6	9053	185.3	8710	
325	OFF	ON	ON	OFF	44	177.1	7794	193.0	8491	186.5	8205	
300	ON	OFF	ON	OFF	40	177.9	7117	193.4	7737	187.3	7491	
275	OFF	OFF	ON	OFF	37	179.1	6628	193.7	7166	188.6	6977	
250	ON	ON	OFF	OFF	33	179.9	5937	194.2	6409	189.4	6250	
200	OFF	ON	OFF	OFF	27	181.2	4891	194.1	5241	190.7	5149	

Installation Steps

6 CCT setting

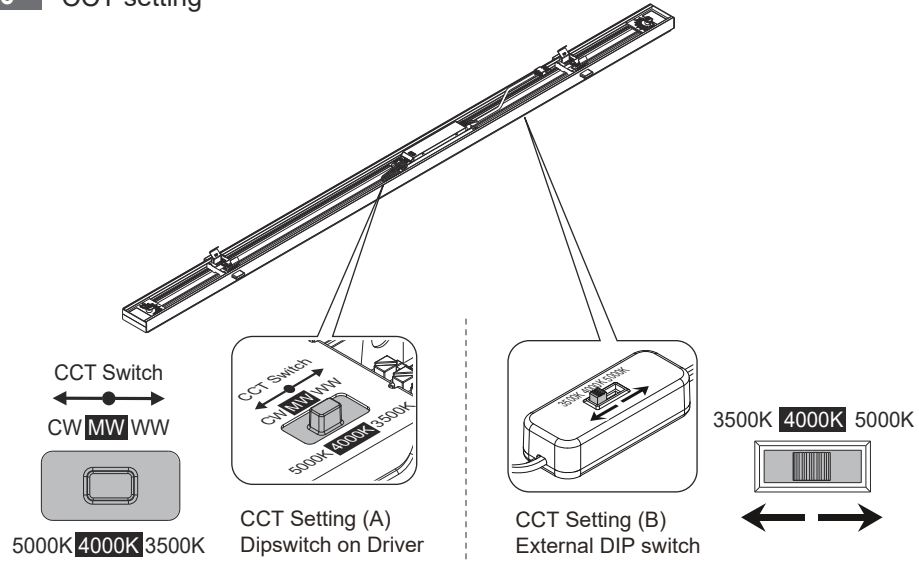

7 Connecting Power Supply

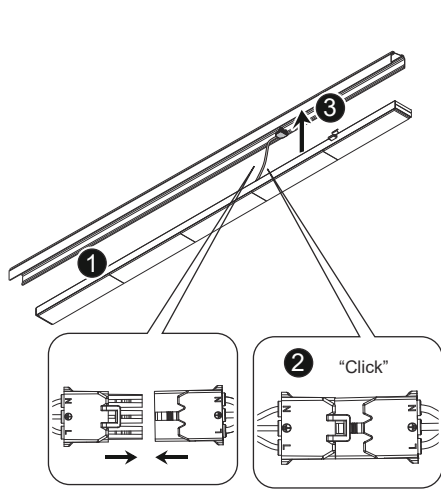

8 Mounting the LED module

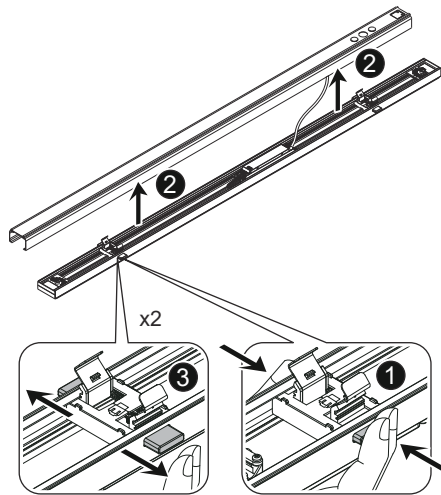

Install extra spring

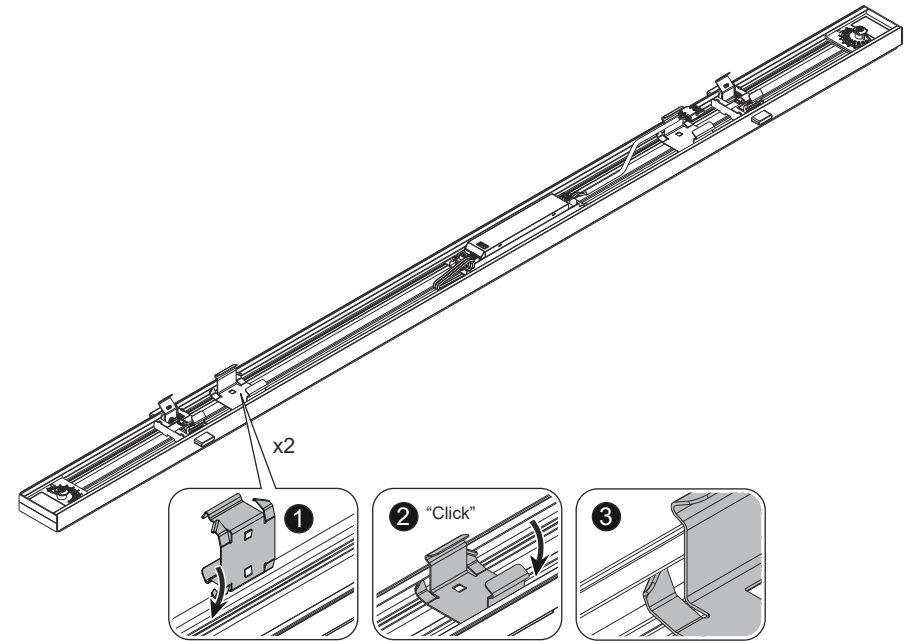

Extra spring compatible list

Picture	Name	Trunk
	Q-STN T8	
	Q-STN T5	
	VLG T5	
	VLG T8	
Picture	Name	Trunk
	DUS	
	5LJ908..	