

IMPORTANT SAFETY NOTES



WARNING

RISK OF ELECTRIC SHOCK

BEFORE YOU BEGIN

- Read these instructions completely and carefully.
- The installation and connection of the luminaire must be done when switched off and by qualified people. Make sure no voltage while installation.

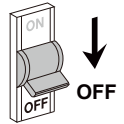

CAUTION

MAINTENANCE

- To avoid injuries, disconnect power to the light and allow the unit to cool down before performing maintenance.
- Perform visual, mechanical and electrical inspections on a regular basis. We recommend routine checks to be made on an annual basis. Frequency of use and environment should determine this.
- The Covers should be cleaned periodically as needed to ensure continued photometric performance. Clean the Cover with a damp, non-abrasive, lintfree cloth. If not sufficient, use mild soap or a liquid cleaner. Do not use an abrasive, strong alkaline or acid cleaner as damage may occur.
- Inspect the topside on the luminaire to ensure that it is free of any obstructions or contamination (i.e. excessive dust build-up). Clean with a non-abrasive cloth if needed.



- Luminaires not suitable for covering with thermally insulating material

ta: -20°C ...+40°C



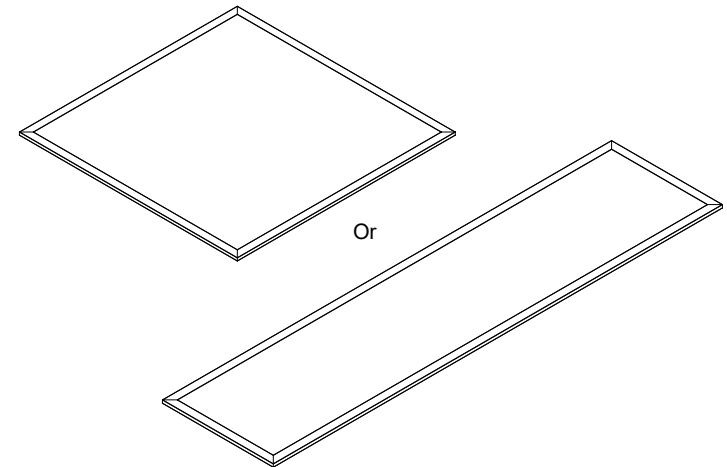

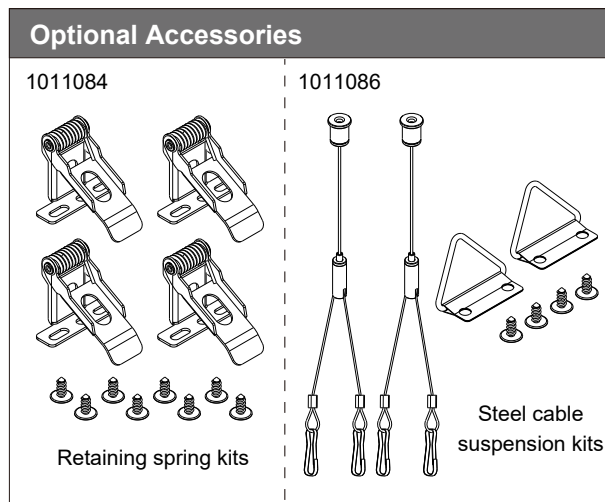
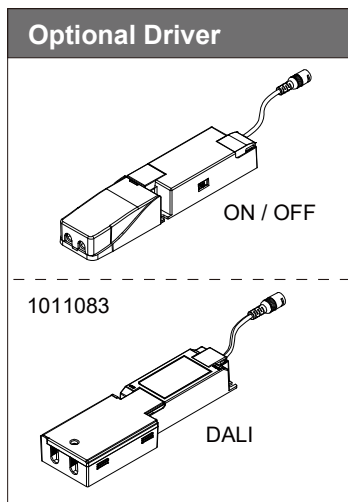
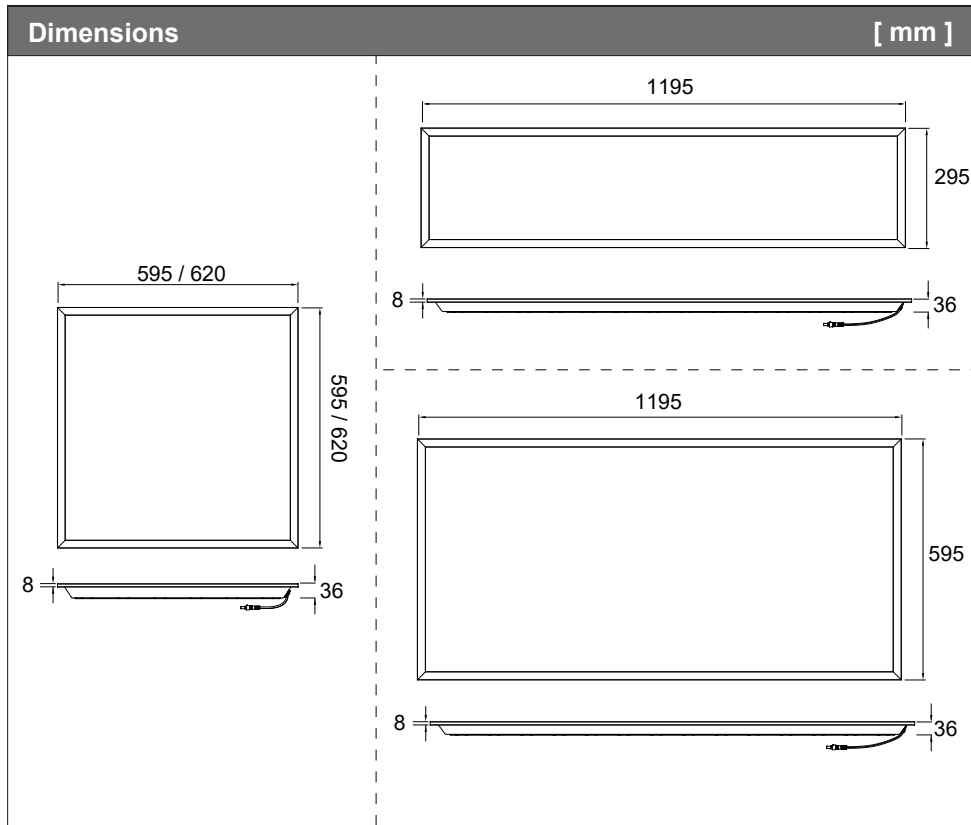



Products





	<p>DA - Henviisning om bortskaffning (EU) Produktet må ikke bortskaffes sammen med husholdningsaffaldet! Produkter med dette symbol skal i henhold til direktivet (WEEE) om affald af elektrisk og elektronisk udstyr bortskaffes via de lokale indsamlingssteder for gamle el-apparater! Gamle batterier og gamle akkumulatører, der ikke er fast indbygget i det gamle apparat, og pærer, som uden at blive beskadiget kan tages ud af det gamle apparat, skal før aflevering på en genbrugsstation fjernes fra det gamle apparat uden beskadigelser. Distributører er i henhold til de gældende lovskrævnede bestemmelser forpligtet til at tage imod gamle apparater fra en slutbruger. Det gamle apparat kan også sendes til følgende adresse til bortskaffelse i Tyskland: SLV GmbH, Technischer Service, Werkstrasse 8-10, 52531 Übach-Palenberg, Tyskland</p>
	<p>PL - Wskazówka dotycząca utylizacji (Unia Europejska) Nie wolno wyrzucać produktu do śmieci domowych! Produkty oznakowane tym symbolem należy utylizować zgodnie z wytycznymi (WEEE) dotyczącymi starych urządzeń elektrycznych i elektronicznych w miejscowych punktach gromadzenia odpadów elektrycznych! Zużyte baterie i akumulatory, które nie są wbudowane w zużyte urządzenie, jak również lampy, które można wyjąć ze zużytego urządzenia w sposób nieniszczący, należy w sposób nieniszczący oddzielić od zużytego urządzenia przed przekazaniem go do punktu zbiórki. Zgodnie z obowiązującymi przepisami dystrybutorzy są zobowiązani do odbioru zużytych urządzeń od użytkownika końcowego. Zużyte urządzenie można również wysłać na poniższy adres w celu utylizacji na terenie Niemiec: SLV GmbH, Technischer Service, Werkstrasse 8-10, 52531 Übach-Palenberg, Niemcy</p>
	<p>RU - Указание по утилизации (Европейский Союз) Не утилизировать прибор вместе с бытовыми отходами! Продукты с подобным обозначением в соотв. с Положением (WEEE) по утилизации старых электрических и электронных приборов необходимо утилизировать через специальные пункты сбора старых электроприборов! Перед доставкой в пункт сбора необходимо отделить от старого устройства неразрушающим способом старые батареи и аккумуляторы, которые не заключены внутри старого устройства, а также лампы, которые можно извлечь из старого устройства неразрушающим способом. Согласно существующему законодательству дистрибьюторы обязаны принимать старые устройства от конечного пользователя. Старый прибор можно также отправить по следующему адресу для утилизации на территории Германии: SLV GmbH, Technischer Service, Werkstrasse 8-10, 52531 Übach-Palenberg, Германия</p>
	<p>SV - Anvisningar för sophantering (Europeiska Unionen) Produkten får ej kastas i hushållssoporna! Produkter som är märkta med denna symbolen ska kastas i enlighet med riktlinjerna (WEEE) för elektriska och elektroniska apparater på de lokala uppsamlingsställen för el- och elektroniksrot. Förbrukade batterier och akkumulatörer, som inte innesluts av aktuellt WEEE, t.ex. lampor, och som på ett icke-destruktivt sätt kan tas loss, ska innan WEEE lämnas till insamlingsstället separeras från den aktuellt WEEE. Distributörer är i enlighet med gällande lagstiftning skyldiga att ta hand om WEEE från slutanvändaren. Den gamla apparaten kan också skickas till följande adress för avfallshantering inom Tyskland: SLV GmbH, Technischer Service, Werkstrasse 8-10, 52531 Übach-Palenberg, Tyskland</p>
	<p>TR - Tasfiye açıklaması (Avrupa Birliği) Ürünü ev çöplüyle birlikte atmayın! Bu sembolü taşıyan ürünler, elektroteknik ve elektronik eski aletlerin yerel elektronik eski aletler toplama yerinde tasfiye edilmesi (WEEE) yönetmeliğine bağlıdır. Eski cihaz kapsamına girmeyen eski piller ve eski akümülatörler ve de eski cihazdan parçalanmadan çıkarılabilen lambalar, kayıt merkezine teslim edilmeden önce eski cihazdan parçalanmadan çıkarılmalıdır. Satıcılar ilgili yasal yükümlülüklerine göre eski cihazları son kullanıcılardan geri almakla yükümlüdür. Eski cihaz Almanya içinde imha edilmek üzere aşağıdaki adrese de gönderilebilir: SLV GmbH, Technischer Service, Werkstrasse 8-10, 52531 Übach-Palenberg, Almanya</p>
	<p>HU - Hulladékkezelés (Európai Unió) A terméket ne a hágyományos háztartási hulladékkal együtt dobja ki! A fenti jellel ellátott termékeket a WEEE, irányelv szerint az elektromos és elektronikus termékek számára kihelyezett hulladékgyűjtőbe tegye! Az olyan elemeket és akkumulátorokat, melyek nem zártan vannak a használt készülékbe helyezve valamint a használt készülékből roncsolás nélkül eltávolítható lámpákat a gyűjtőhelyen történő leadást megelőzően károsítás nélkül el kell távolítani. A forgalmazók a vonatkozó jogi előírásoknak megfelelően kötelesek visszavenni a végfelhasználótól a használt készülékeket. A régi készüléket a következő címre is elküldheti Németországon belüli ártalmatlanításra: SLV GmbH, Technischer Service, Werkstrasse 8-10, 52531 Übach-Palenberg, Németország</p>

Disposal Note Type B 17.12.2024

	<p>DE - Entsorgung (Europäische Union) Produkt nicht im Hausmüll entsorgen! Produkte mit diesem Symbol sind entsprechend der Richtlinie(WEEE) über Elektro- und Elektronik-Altgeräte über die örtlichen Sammelstellen für Elektro-Altgeräte zu entsorgen! Altbatterien und Altakkumulatoren, die nicht vom Altgerät umschlossen sind, sowie Lampen, die zerstörungsfrei aus dem Altgerät entnommen werden können, sind vor der Abgabe an einer Erfassungsstelle vom Altgerät zerstörungsfrei zu trennen. Vertreiber sind, nach den jeweiligen gesetzlichen Verpflichtungen, verpflichtet Altgeräte von einem Endnutzer zurückzunehmen. Zur Entsorgung kann das Altgerät innerhalb Deutschlands auch an folgende Adresse versendet werden: SLV GmbH, Technischer Service, Werkstrasse 8-10, 52531 Übach-Palenberg</p>
	<p>EN - Disposal (European Union) Do not dispose the product with the regular household waste! Products marked with this sign must be disposed according to the directive (WEEE) on electrical and electronic devices at local collection points for such devices! Waste batteries and accumulators, which are not enclosed by the waste equipment, and lamps, which are removable non-destructively from the waste equipment are to be separated non-destructively from the waste equipment before turning to a local collection point. Distributors are, according to particular legislation, obligated to take back waste equipment from the final holder. For disposal within Germany the waste equipment may be send to the following address: SLV GmbH, Technischer Service, Werkstrasse 8-10, 52531 Übach-Palenberg, Germany</p>
	<p>FR - Information de recyclage (Union européenne) Ne recyclez pas le produit avec les ordures ménagères ! Les produits qui présentent ce symbole sont à recycler suivant la directive (WEEE) relative aux déchets d'équipements électriques et électroniques, via des points de collecte pour appareils électriques usagés ! Les piles et accus usagés qui ne sont pas incorporés dans l'appareil usagé, ainsi que les lampes qui peuvent être retirées de l'appareil usagé sans être détruites, doivent être retirés de l'appareil usagé sans être détruits avant d'être remis au Recycparc. Conformément à leurs obligations légales respectives, les distributeurs sont tenus de reprendre les appareils usagés d'un utilisateur final.</p> <div style="display: flex; justify-content: space-around; align-items: center;"> <div style="text-align: center;">  <p>FR Cet appareil se recycle</p> <p>À DÉPOSER EN MAGASIN OU À DÉPOSER EN DÉCHÈTERIE</p> <p>Points de collecte sur www.quefairedemesdechets.fr Privilégiez la réparation ou le don de votre appareil !</p> </div> <div style="text-align: center;">  <p>FR Cette batterie se recycle</p> <p>À DÉPOSER EN MAGASIN OU À DÉPOSER EN DÉCHÈTERIE</p> <p>Points de collecte sur www.quefairedemesdechets.fr</p> </div> </div> <p>Pour l'élimination, l'appareil usagé peut également être envoyé en Allemagne à l'adresse suivante : SLV GmbH, Technischer Service, Werkstrasse 8-10, 52531 Übach-Palenberg, Allemagne</p>
	<p>ES - Indicaciones para la eliminación (Unión Europea) ¡No tirar el producto con la basura doméstica! Los productos con este símbolo deben eliminarse, de acuerdo con la directiva (WEEE) sobre residuos de aparatos eléctricos y electrónicos, llevándolos a los puntos de recogida selectiva de aparatos eléctricos y electrónicos locales. Las baterías y los acumuladores recargables que no se hallen protegidos por el aparato viejo, así como las lámparas, extraídas sin romperlas del aparato viejo, deben desmontarse sin llegar a alterarlos antes de entregarlos a un punto de recogida. Los distribuidores están obligados a recoger los aparatos viejos de un usuario final según las obligaciones legales pertinentes. El aparato antiguo también puede enviarse a la siguiente dirección para su eliminación dentro de Alemania: SLV GmbH, Technischer Service, Werkstrasse 8-10, 52531 Übach-Palenberg, Alemania</p>
	<p>IT - Istruzioni per lo smaltimento (Unione Europea) Non smaltire il prodotto con i rifiuti domestici! I prodotti con questo simbolo devono essere smaltiti, nel rispetto della Direttiva (WEEE) sui rifiuti di apparecchiature elettriche ed elettroniche, nei punti di raccolta locale ad essi adibiti! Verificare sul sito www.slvitalia.it il corretto metodo di smaltimento del presente materiale. Le batterie e gli accumulatori usati non racchiusi nell'apparecchio usato e le lampade rimovibili dall'apparecchio usato senza venire distrutte, devono essere divise dall'apparecchio usato senza venire distrutte, prima di essere consegnate in un punto di raccolta. I rivenditori sono tenuti, secondo i rispettivi obblighi legali, a ritirare gli apparecchi usati dal consumatore finale. Il vecchio apparecchio può anche essere inviato al seguente indirizzo per lo smaltimento in Germania: SLV GmbH, Technischer Service, Werkstrasse 8-10, 52531 Übach-Palenberg, Germania</p>
	<p>NL - Afvalverwijdering (Europese Unie) Het product niet via het huishoudelijk afval weggoen! Producten met dit symbool dienen in overeenstemming met richtlijn (WEEE) via elektrische en elektronische apparatuur bij de plaatselijke inzamelpunten voor elektrisch afval te worden verwijderd! Afgedankte accu's en accumulators die niet in het afgedankte apparaat zijn ingebouwd, zoals lampen die zonder beschadigingen uit het apparaat kunnen worden verwijderd, dienen voorafgaand aan de afgifte aan de betreffende instantie voor afgedankt apparaat, niet-destructief verwijderd te worden. De verkopers zijn op basis van de betreffende wettelijke regelgeving, verplicht afgedankte apparaten van een eindgebruiker terug te nemen. Het oude apparaat kan ook naar het volgende adres worden gestuurd voor verwijdering binnen Duitsland: SLV GmbH, Technischer Service, Werkstrasse 8-10, 52531 Übach-Palenberg, Duitsland</p>

Installation Steps

A Embedded installation

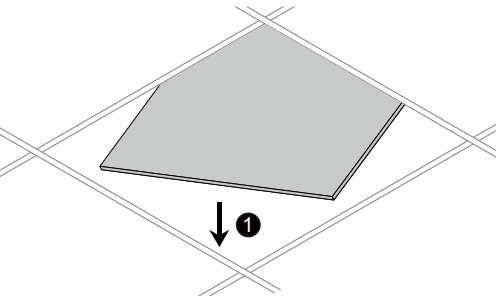
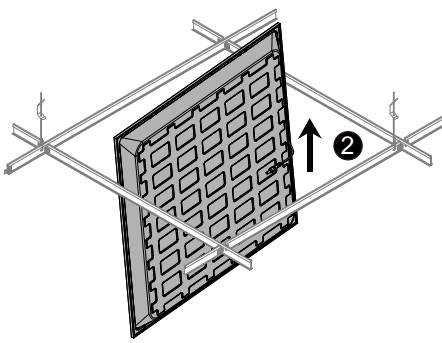
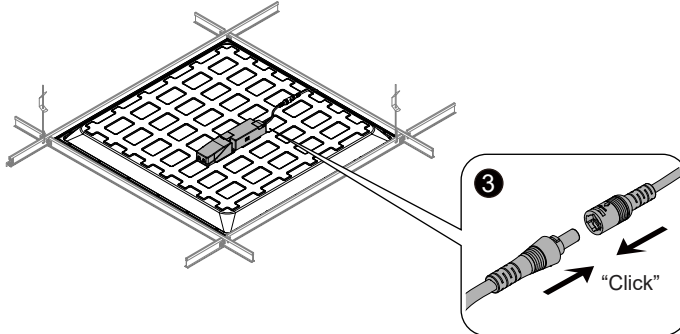
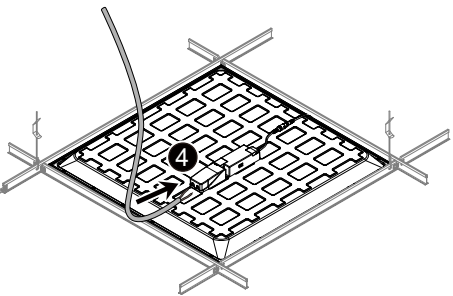
1. Remove the ceiling drywall
 
2. Place the luminaire on the keel frame
 
3. Connecting Driver
 
4. Connecting Power Supply
 

Installation Steps

B Installation of retaining spring

1. Drill holes in the ceiling according to the size of the luminaire

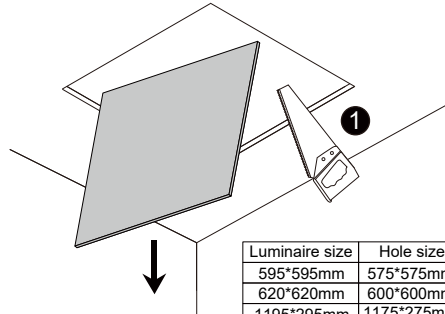

Luminaire size	Hole size
595*595mm	575*575mm
620*620mm	600*600mm
1195*295mm	1175*275mm
1195*595mm	1175*575mm

2. Fix the retaining spring to the luminaire with screws

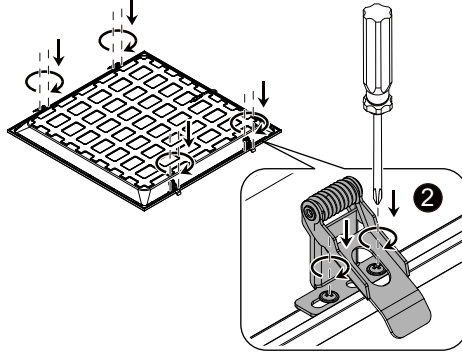

3. Connecting Driver

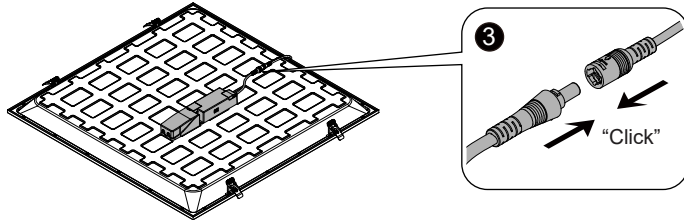

4. Connecting Power Supply

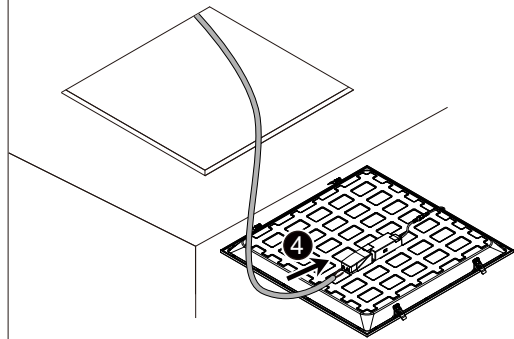

5. Straighten the retaining spring and fasten the lamp into the ceiling

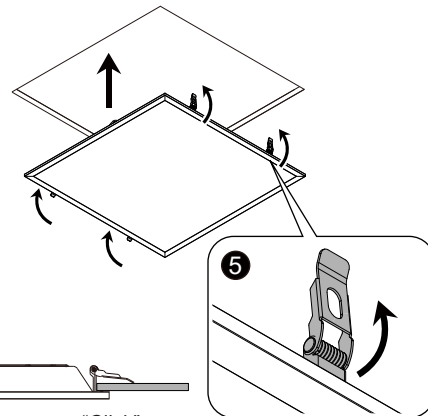

Connecting Power Supply

B DALI

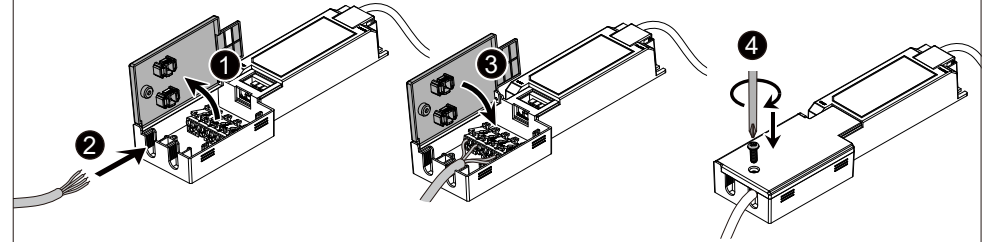

4 Wires specification:

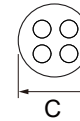

Outer diameter: $\varnothing 8\text{mm} \leq C \leq 10\text{mm}$
Core of cable: $4 \times 0.75 \sim 1.5\text{mm}^2$

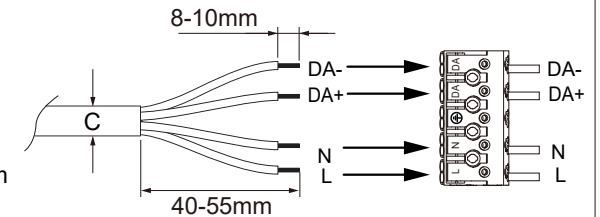

pushDIM dimming application

Wiring diagram

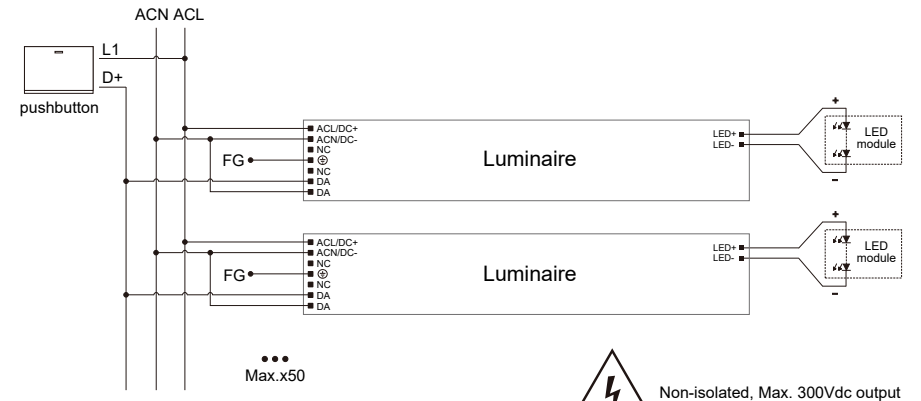

Switch to the pushDIM dimming mode

- According to the wiring diagram of the pushDIM dimming application, short press the pushbutton 5 times quickly within 3s, the driver will automatically switch to the pushDIM dimming mode.
- After switch to the pushDIM control mode, CorridorDIM mode will be automatically closed.

Connecting Power Supply

A ON / OFF

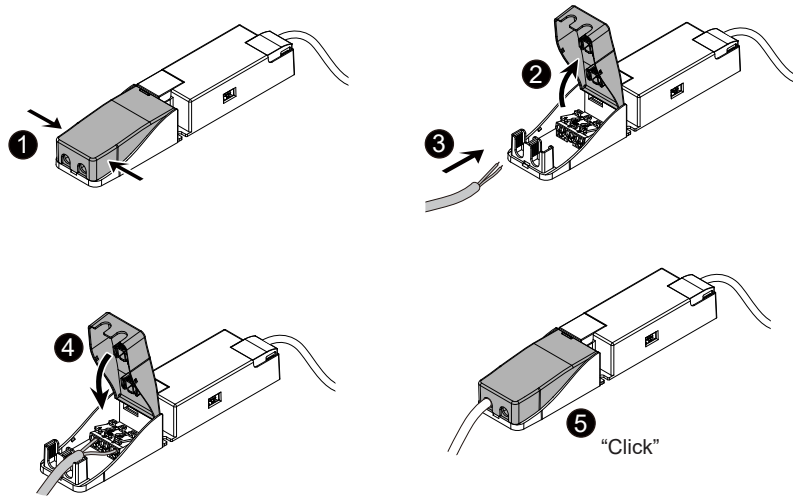

2 Wires specification:

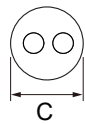

Outer diameter: $\varnothing 8\text{mm} \leq C \leq 10\text{mm}$

Core of cable: $2 \times 0.75 \sim 2.5\text{mm}^2$

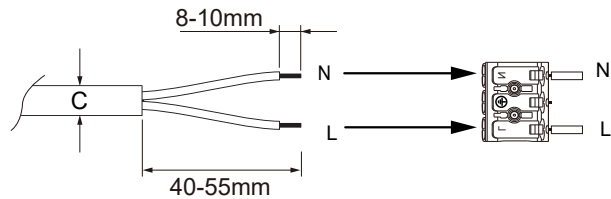

Installation Steps

C Suspended mounted

1. Measure the distance and drill holes to suspend the steel cable suspension kits

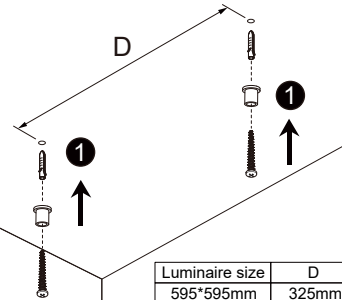

Luminaire size	D
595*595mm	325mm
620*620mm	313mm
1195*295mm	927mm
1195*595mm	927mm

2. Fix the triangular lifting lugs to the luminaire with screws

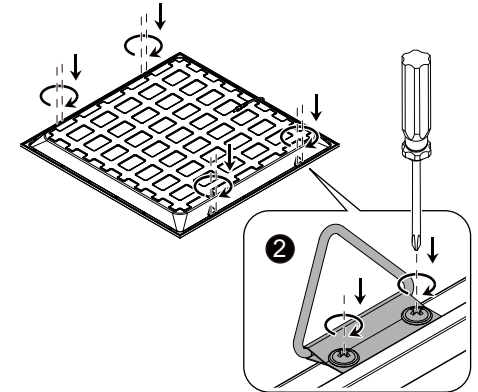

3. Clamp the steel cable onto the triangular lifting lugs

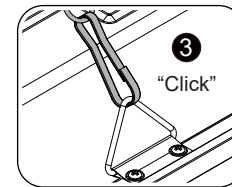

4. Fix the steel cable kit to the ceiling

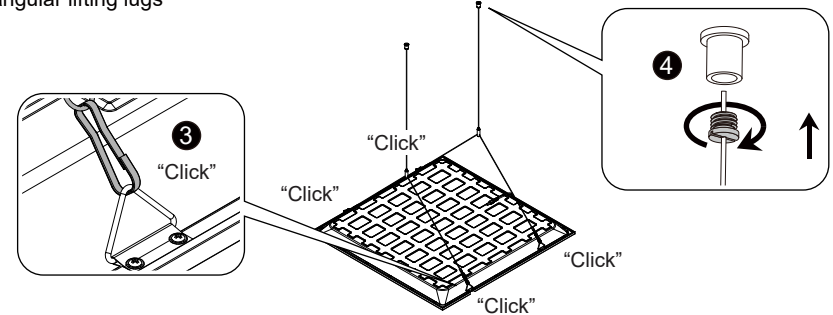

5. Connecting Driver

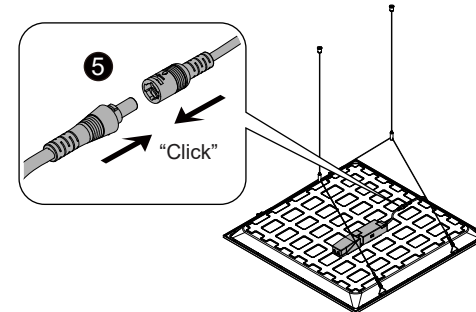

6. Connecting Power Supply

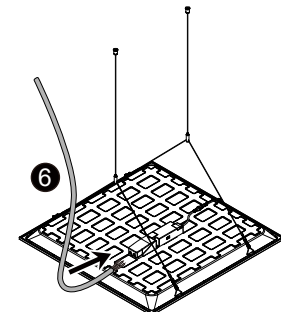

Wattage setting

A ON / OFF

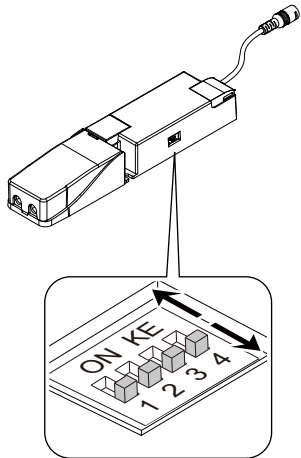

Output current [mA]	Switch position (ON/OFF)				Rated Power [W]	1010109, 1010566 1010747, 1010751		1010110, 1010567 1010748, 1010752	
	1	2	3	4		4000K		3000K	
						Light effect [lm/W]	Flux [lm]	Light effect [lm/W]	Flux [lm]
500	OFF	OFF	OFF	OFF	21	197.4	4145	187.5	3937
550	ON	OFF	OFF	OFF	23	196.7	4524	186.8	4297
600	OFF	ON	OFF	OFF	25	195.9	4898	186.1	4653
650	OFF	OFF	ON	OFF	27	195.1	5268	185.4	5005
700	ON	OFF	ON	OFF	29	194.1	5628	184.4	5346
750	OFF	ON	ON	OFF	31	193.0	5984	183.4	5685
800	OFF	OFF	OFF	ON	33	191.9	6333	182.3	6017
850	ON	OFF	OFF	ON	35	190.9	6680	181.3	6346
900	OFF	ON	OFF	ON	38	189.8	7212	180.3	6851
950	OFF	OFF	ON	ON	40	188.5	7540	179.1	7163
1000	ON	OFF	ON	ON	42	187.3	7868	178.0	7474

Output current [mA]	Switch position (ON/OFF)				Rated Power [W]	1010113, 1010570		1010114, 1010571	
	1	2	3	4		4000K		3000K	
						Light effect [lm/W]	Flux [lm]	Light effect [lm/W]	Flux [lm]
500	OFF	OFF	OFF	OFF	21	193.0	4052	183.3	3849
550	ON	OFF	OFF	OFF	23	192.2	4421	182.6	4200
600	OFF	ON	OFF	OFF	25	191.1	4778	181.6	4540
650	OFF	OFF	ON	OFF	27	190.2	5137	180.7	4880
700	ON	OFF	ON	OFF	29	189.5	5495	180.0	5220
750	OFF	ON	ON	OFF	31	188.4	5840	179.0	5548
800	OFF	OFF	OFF	ON	33	187.7	6192	178.3	5883
850	ON	OFF	OFF	ON	35	186.4	6525	177.1	6199
900	OFF	ON	OFF	ON	38	185.3	7043	176.1	6691
950	OFF	OFF	ON	ON	40	184.1	7366	174.9	6997
1000	ON	OFF	ON	ON	42	183.0	7686	173.9	7302

Output current [mA]	Switch position (ON/OFF)				Rated Power [W]	1010117, 1010574		1010118, 1010575	
	1	2	3	4		4000K		3000K	
						Light effect [lm/W]	Flux [lm]	Light effect [lm/W]	Flux [lm]
500	OFF	OFF	OFF	OFF	21	200.1	4202	190.1	3992
550	ON	OFF	OFF	OFF	23	199.6	4590	189.6	4360
600	OFF	ON	OFF	OFF	25	200.0	5000	190.0	4750
650	OFF	OFF	ON	OFF	27	199.2	5379	189.3	5110
700	ON	OFF	ON	OFF	29	198.6	5761	188.7	5473
750	OFF	ON	ON	OFF	31	197.9	6136	188.0	5829
800	OFF	OFF	OFF	ON	33	197.1	6505	187.3	6179
850	ON	OFF	OFF	ON	35	196.7	6885	186.9	6541
900	OFF	ON	OFF	ON	37	196.0	7252	186.2	6889
950	OFF	OFF	ON	ON	39	195.2	7612	185.4	7232
1000	ON	OFF	ON	ON	41	194.1	7959	184.4	7561

Wattage setting

B DALI

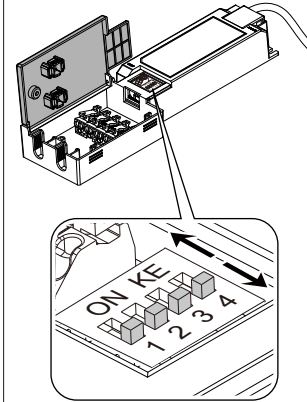

Output current [mA]	Switch position (ON/OFF)				Rated Power [W]	1010111, 1010568 1010749, 1010753		1010112, 1010569 1010750, 1010754	
	1	2	3	4		4000K		3000K	
						Light effect [lm/W]	Flux [lm]	Light effect [lm/W]	Flux [lm]
600	OFF	ON	ON	ON	26	182.7	4751	173.6	4514
650	ON	OFF	ON	ON	28	182.7	5116	173.6	4860
700	OFF	OFF	ON	ON	30	182.7	5482	173.6	5208
750	OFF	ON	OFF	ON	33	182.1	6010	173.0	5710
800	OFF	OFF	OFF	ON	35	181.7	6361	172.7	6043
850	ON	ON	ON	OFF	37	180.9	6693	171.8	6358
900	OFF	OFF	ON	OFF	39	180.1	7022	171.1	6671
950	OFF	ON	OFF	OFF	41	179.2	7348	170.3	6981

Output current [mA]	Switch position (ON/OFF)				Rated Power [W]	1010115, 1010572		1010116, 1010573	
	1	2	3	4		4000K		3000K	
						Light effect [lm/W]	Flux [lm]	Light effect [lm/W]	Flux [lm]
600	OFF	ON	ON	ON	26	179.8	4675	170.8	4441
650	ON	OFF	ON	ON	28	179.3	5021	170.3	4770
700	OFF	OFF	ON	ON	30	179.2	5375	170.2	5107
750	OFF	ON	OFF	ON	33	178.8	5899	169.8	5604
800	OFF	OFF	OFF	ON	35	178.4	6242	169.4	5930
850	ON	ON	ON	OFF	37	177.6	6569	168.7	6241
900	OFF	OFF	ON	OFF	39	176.9	6901	168.1	6556
950	OFF	ON	OFF	OFF	41	176.1	7219	167.3	6858

Output current [mA]	Switch position (ON/OFF)				Rated Power [W]	1010119, 1010576		1010120, 1010577	
	1	2	3	4		4000K		3000K	
						Light effect [lm/W]	Flux [lm]	Light effect [lm/W]	Flux [lm]
600	OFF	ON	ON	ON	26	187.7	4879	178.3	4635
650	ON	OFF	ON	ON	28	187.8	5258	178.4	4995
700	OFF	OFF	ON	ON	30	187.8	5635	178.4	5353
750	OFF	ON	OFF	ON	32	187.7	6006	178.3	5706
800	OFF	OFF	OFF	ON	34	187.3	6368	177.9	6050
850	ON	ON	ON	OFF	36	187.1	6734	177.7	6398
900	OFF	OFF	ON	OFF	38	186.8	7097	177.4	6742
950	OFF	ON	OFF	OFF	41	186.1	7629	176.8	7248